



Acoustic Systems

Wall | Ceiling



„... Important things are not said aloud, but quietly.“

© Herbert Henry Asquith

Acoustic Systems

Content

Acoustic-Lightboard®

Meets the highest requirements in the field of sound insulation

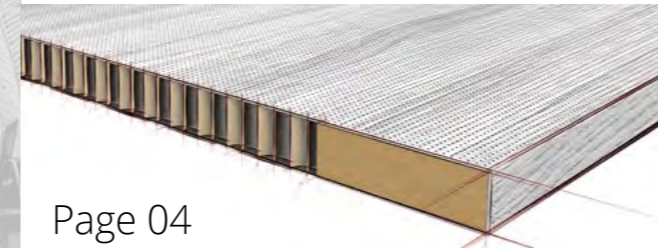

Page 04

Acoustic-Baffles

Striking lines for excellent acoustics

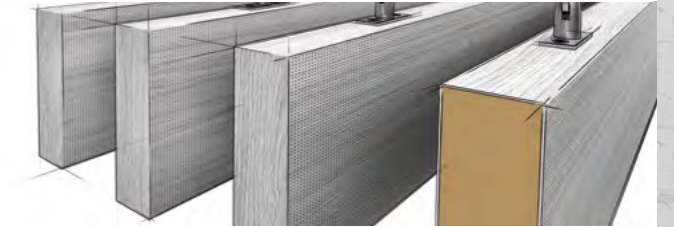

Page 06

Acoustic-CompactBoard®

Acoustic panels for interior design

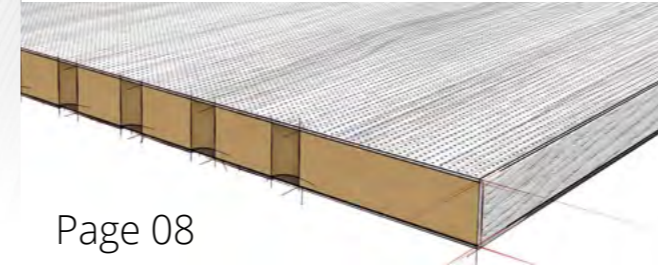

Page 08

Acoustic-CompactPanel®

Ready-made design panel for unlimited design options



Page 10

Acoustic-RibPanel

Acoustic comfort with exclusive design

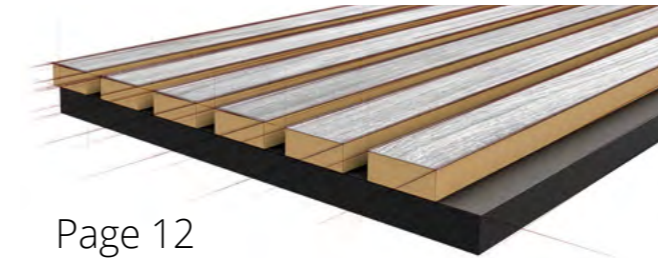

Page 12

Acoustic-RibPanel Slim

Acoustic comfort, discreet design

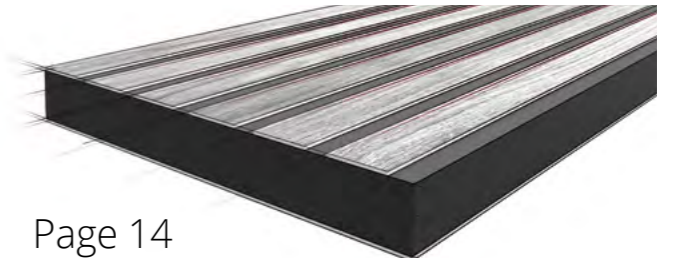

Page 14

Acoustic-Grilles

Space design with pleasant sound effects

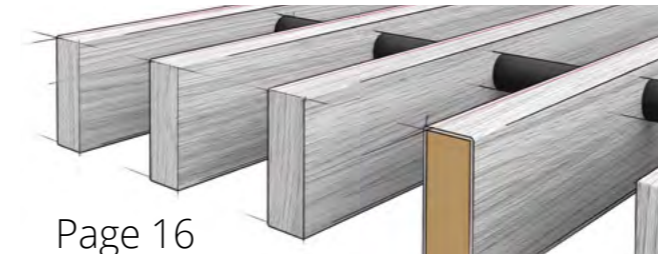

Page 16

Acoustics | Surfaces

A wide range of acoustic solutions and design surfaces for sound-sensitive rooms



Page 18

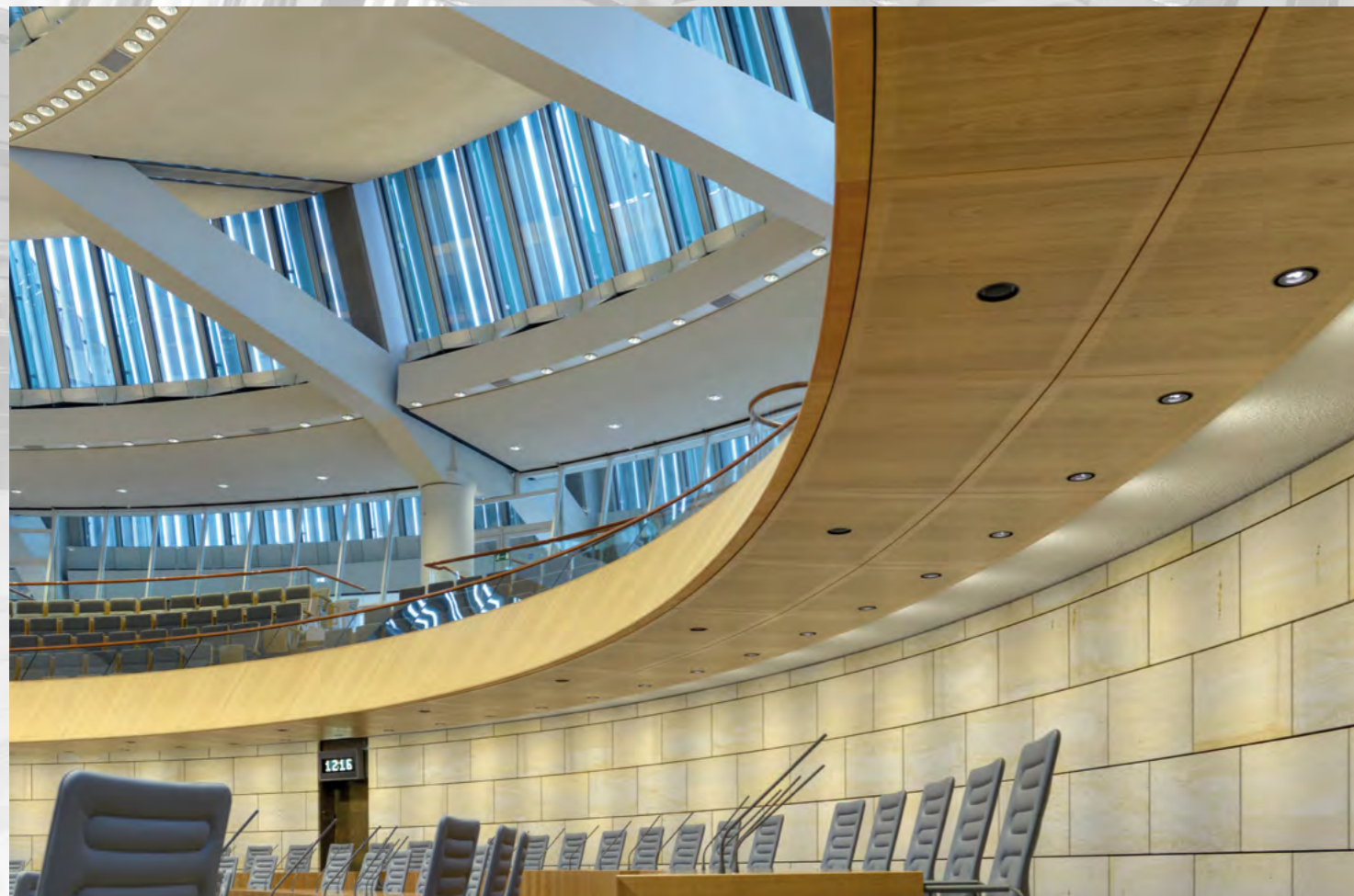

Lightweight



High sound absorption



Design variety

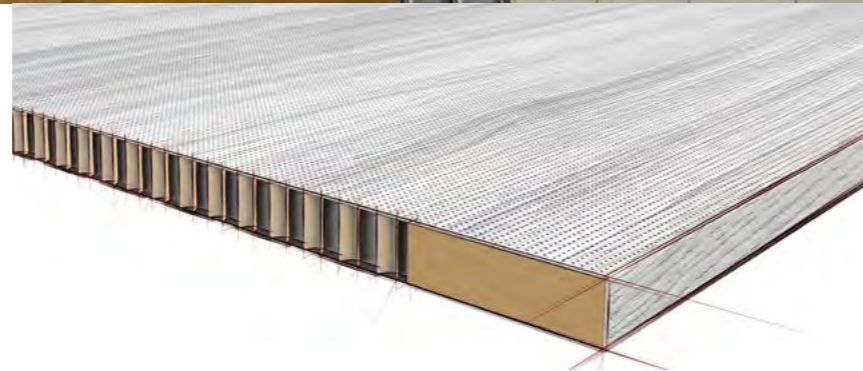

Acoustic-Lightboard®

Meets the highest requirements in the sound insulation

Acoustic-Lightboard® impresses with high sound absorption and low weight. The combination of a microperforated surface with a close-meshed honeycomb core and the surrounding wood-based frame makes this panel suitable for a wide range of applications. Thanks to customer-specific fabrication, the Acoustic-Lightboard® is always visually and technically adapted to your needs.

Fire protection

Our Acoustic-Lightboard® products meet most high fire protection requirements.

B-s1-d0
B-s2-d0
Class A

DIN 13501-1
ASTM E 84

Possible surfaces

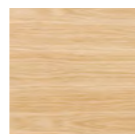
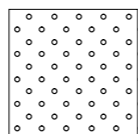
HPL/stained/
lacqueredReal wood
veneers

Perforations

Material structure

With diameters from 1.5 to 0.5 mm (0.06" to 0.02"), all laminates and veneers can be perforated with the highest precision. The front and rear decks of Acoustic-Lightboard® elements are available with many various perforations.

1. Surface material front side
2. Close-meshed honeycomb structure made of recycled cardboard
3. Wood-based frame (particle board, MDF)
4. Black acoustic fleece
5. Surface material back side
6. Edging (in veneer, ABS, PP, melamine etc. options)

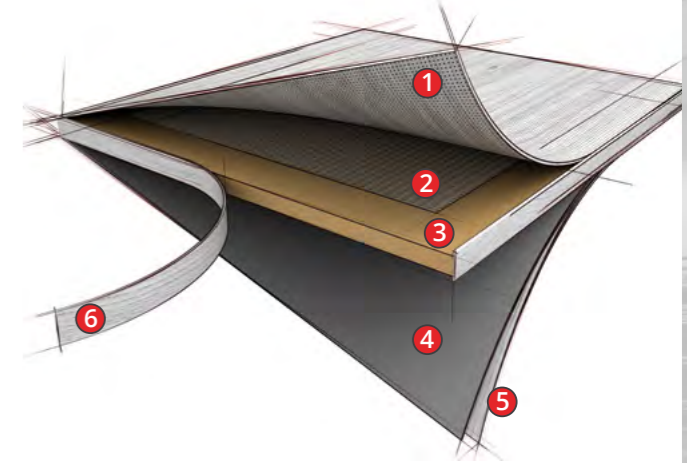

Mounting

Due to its low weight, the Acoustic-Lightboard® offers numerous applications and installation options. In addition to use as furniture components also for quick and easy wall mounting, e.g. using suspension profiles, it can also be installed as a ceiling element in all common T-profile grid systems. In this case, the panel edges can be adapted to the desired joint characteristics.

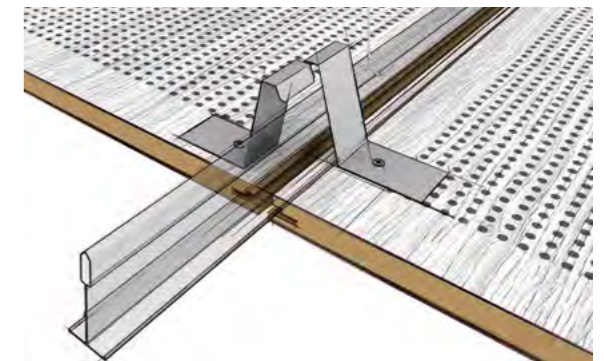

Technical data

Length (max.)	3000 mm (118.1" - depending on selected surface material)
Width (max.)	1250 mm (49.2" - depending on selected surface material)
Thickness (max.)	50 mm (≈2")
Weight	6,5 - 12,5 kg/m ² (1.33 - 2.56 lbs/ft ²) (depending on selected surface material and dimensions)

Other dimensions and constructions on request.

Acoustics

Micro-perforations with 0.5 to 1.5 mm (0.02" to 0.06") diameter in various geometric arrangements allow absorption of the incident sound. With up to 320,000 holes per square meter and its close-meshed honeycomb structure, the Acoustic-Lightboard® ensures pleasant acoustics from office spaces to large halls.

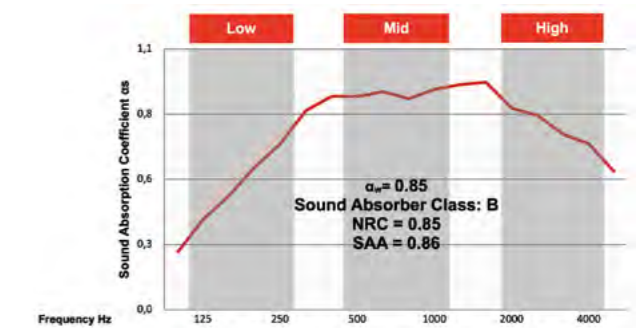

Further information

You can find all the information you need about Acoustic-Lightboard® online.



>>> Website Acoustic-Lightboard®

Questions? Get personal advice now.

+49 5428 9420-0





Design variety



High sound absorption

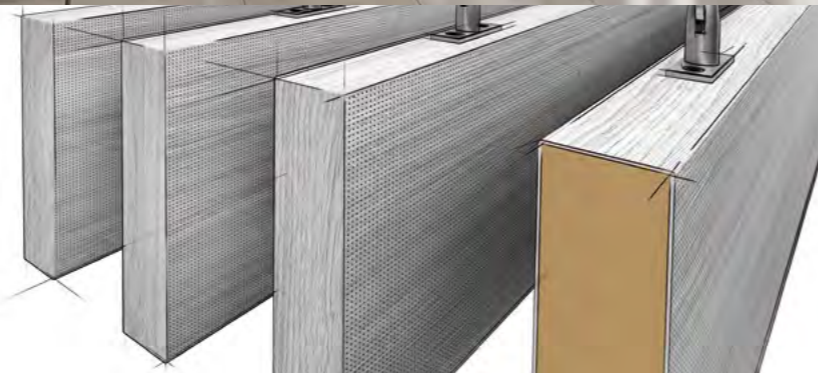

Acoustic-Baffles

Striking lines for fine acoustics

Acoustic-Baffles are vertically suspended acoustic louvers that can be produced individually with different dimensions, surfaces and perforations. The type of installation can be adapted according to your requirements.

Possible surfaces



HPL / stained / lacquered



Real wood veneers

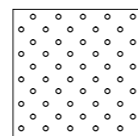

Perforations

Material structure

Acoustic-Baffles consist of an acoustically optimized carrier material, with various perforated surfaces.

1. Surface material front side
2. Close-meshed honeycomb structure made of recycled cardboard
3. Wood-based frame (particle board / MDF)
4. Black acoustic fleece
5. Surface material back side
6. Edging (veneer, ABS, PP, melamine etc. options)



Mounting

Acoustic-Baffles can be easily mounted using a variety of fasteners. Among other things, individual installation can be carried out by means of wire suspensions on existing ceilings. In addition to free placement in the room, this mounting variant also allows the suspension heights of the Acoustic-Baffles to be adjusted. Alternatively, grid ceiling profiles can be used for uniform and large-scale Acoustic-Baffles installation.

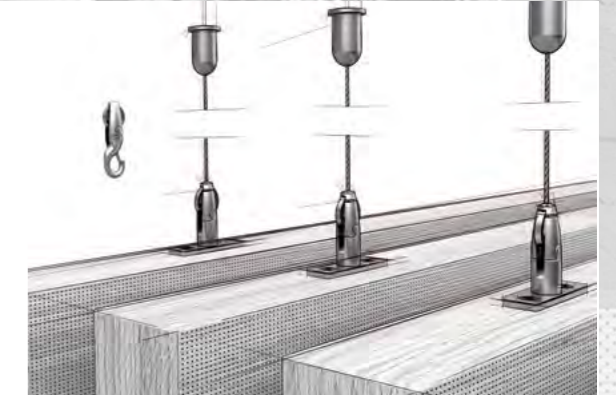

Technical data

Length (max.)	3000 mm (118.1")
Width (max.)	600 mm (≈24")
Thickness (max.)	50 mm (≈2")
Weight	10 - 20 kg/m ² (2.05 - 4.10 lbs/ft ²) (depending on selected surface materials and dimensions)

Other dimensions and constructions on request.

Acoustics

High spaces with wide ceiling areas offer an ideal starting point for room acoustic optimization with Acoustic Baffles. Incident sound is predominantly absorbed and remaining sound energy is diffusely reflected due to the vertical orientation. The acoustic effectiveness can be influenced by the width and spacing of the baffles.

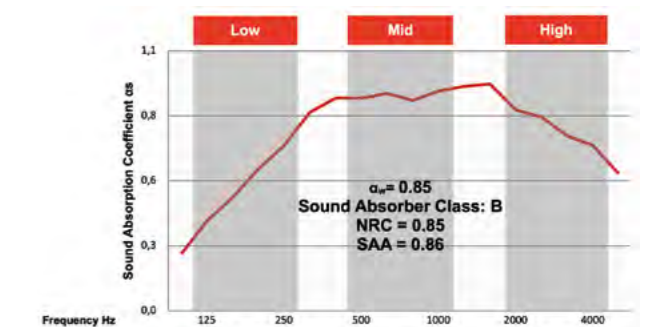

Further information

You can find all the information you need about Acoustic-Baffles online.



>>> Website Acoustic-Baffles

Questions? Get personal advice now.

+49 5428 9420-0



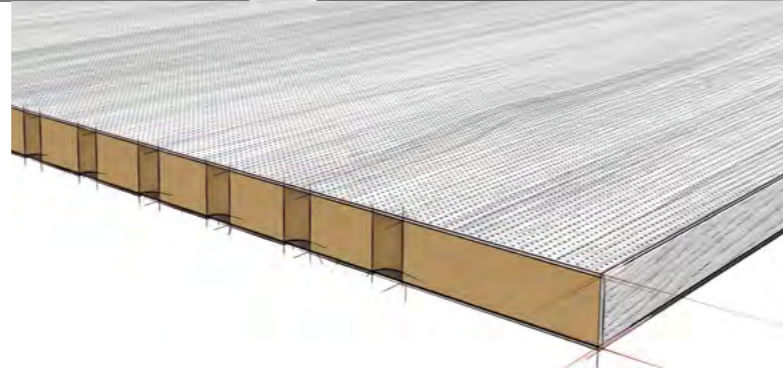

Acoustic-CompactBoard®

Acoustic panels for interior design

Acoustic-CompactBoard®, the classic design for large-areas, acoustically effective wall and ceiling panels. The construction of acoustically optimized carrier board and micro-perforated surfaces make this product a true all-rounder. The Acoustic-CompactBoard® can be tailored to your specific needs, both visually and technically adapted to your needs.

Possible surfaces



HPL/stained/lacquered



Real wood veneers

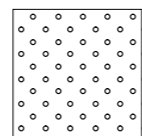

Perforations

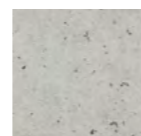

LightBeton®

Material structure

Acoustic-CompactBoard® consists of an acoustically optimized carrier material which is covered with the desired perforated surfaces.

1. Surface material front side
2. Natural MDF, drilled
3. Black acoustic fleece
4. Surface material back side
5. Edging (veneer, ABS, PP, melamine etc. optional)

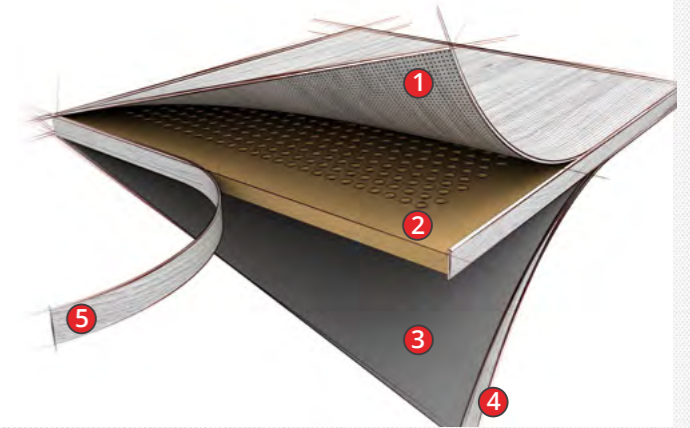

Mounting

The Acoustic-CompactBoard® can be mounted easily and quickly on large wall surfaces, e.g. using attachment profiles. For this purpose, short panel clips are attached to the back of the panels, with which they can be easily hooked into the continuous profiles of the substructure.



Technical data

Length (max.)	3000 mm (118.1" - depending on selected surface material)
Width (max.)	1250 mm (49.2" - depending on the selected surface material)
Thickness	17,5 mm (11/16")
Weight	approx. 12.5 kg/m ² (2.56 lbs/ft ²) (depending on selected surface material and dimensions)

Other dimensions and constructions on request.

Acoustics

Due to the interaction of the acoustically optimized carrier board with the micro-perforated face sheets, the Acoustic-CompactBoard® ensures pleasant room acoustics.

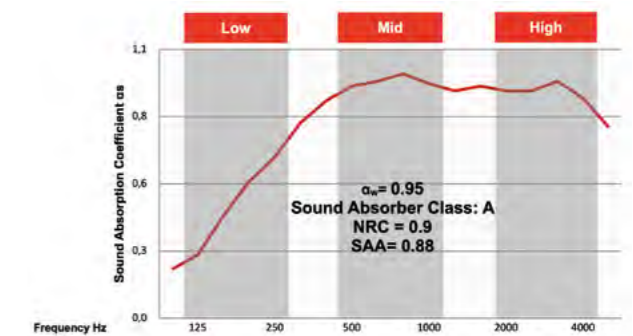

Further information

You can find all the information you need about Acoustic-CompactBoard® online.



>>> Website Acoustic-CompactBoard®

Questions? Get personal advice now.

+49 5428 9420-0





Easy processing



High sound absorption



Design variety



Acoustic-CompactPanel®

Ready-made design panel for unlimited design options

The Acoustic-CompactPanel® stands for linear design, paired with many possibilities in sophisticated and fast interior design. The Acoustic-CompactPanel® is available as a fully assembled panel in fixed formats and as a lamella with a tongue-and-groove profile on the long side. The profiling enables large-area installations with seamless and invisible transitions for a smooth character.

Possible surfaces



HPL / stained / lacquered / Melamine

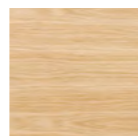

Real wood veneers

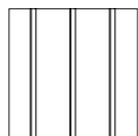

Slitting

Material structure

An MDF board is used as a support, which is slotted on the visible side in different variants and drilled on the reverse side. The surface and edge finish is freely selectable - a stained lacquer finish according to RAL/NCS is just as possible as a finish with real wood veneer, melamine surface or HPL coating.

1. Surface material front side
2. Brown MDF
3. Black acoustic fleece

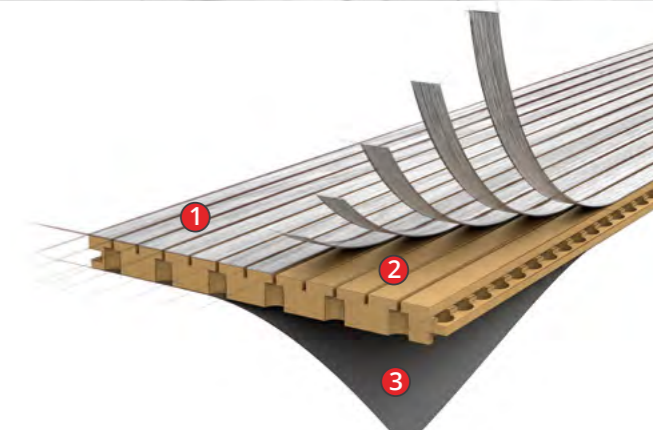

Mounting

Acoustic-CompactPanel® can be used to cover large areas with an endless character quickly and easily. For this purpose, the Acoustic-CompactPanel® can be easily mounted as a lamella on the substructure using pneumatic nailers or profile claws.



Technical data

Design Panel in fixed format:

Length (max.) 2780 mm (109.5")

Width (max.) 1240 mm (48.8")

Execution lamella:

Length (max.) 2780 mm (109.5")

Width (max.) 192 mm (≈7.5" - cover width)

Thickness 16 - 19 mm (5/8 to 3/4")

Weight 9 - 10.5 kg/m² (1.84 - 2.15 lbs/ft²)
(depending on selected surface material and dimensions)

Other dimensions and constructions on request.

Acoustics

The slits of the Acoustic-CompactPanel® of 2 - 4 mm (0.08" to 0.16") width are open on the back side to absorb the sound. Depending on the selected slit, incident sound is absorbed in the slit area or reflected from the surface. Thus, in addition to the desired appearance, the selected slit also influences the acoustic properties.

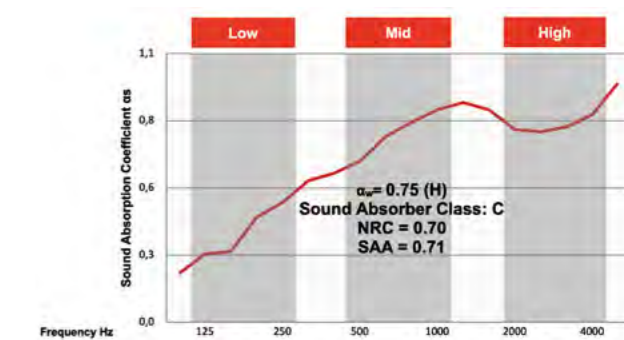

Further information

You can find all the information you need about Acoustic-CompactPanel® online.



>>> Website Acoustic-CompactPanel®

Questions? Get personal advice now.

+49 5428 9420-0





- 
Easy processing
- 
High sound absorption
- 
Design variety



Acoustic-RibPanel

Acoustic comfort with exclusive design

Acoustic-RibPanels consist of wood-based panels that are individually manufactured with different surfaces and fixed to an acoustic felt support with appropriate spacing. These ready-to-use elements can be easily installed or further processed if required. Acoustic-RibPanels can be installed as accent panels, but also with a seamless character without visual transitions.

Possible surfaces



HPL / stained / lacquered

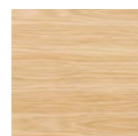

Real wood veneers

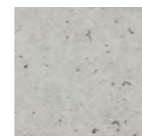

LightBeton®

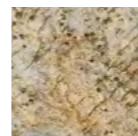

StoneVeneer



Felt

Material structure

Acoustic-RibPanels consist of lamellas, which are individually manufactured with different surfaces and fixed on acoustic felt panels.

1. Surface material front side
2. Natural MDF (alternatives on request)
3. PET felt black (alternatives on request)

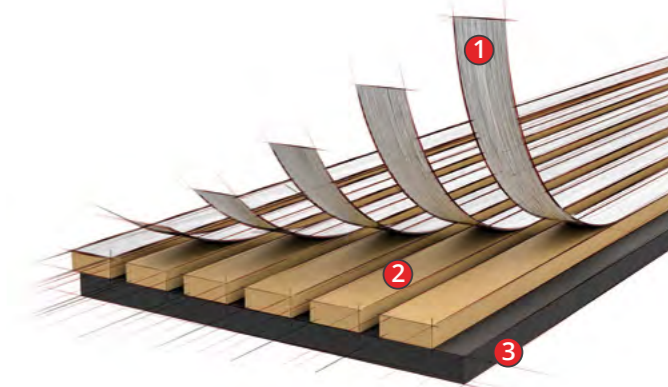

Mounting

Acoustic-RibPanels can be easily mounted by nailing, stapling and screwing through the felt support or by fixing fasteners on the back. Direct bonding by means of strong mounting adhesive is also possible.



Technical data

Length	2800 mm (110.2")
Width	210 mm (8.25")
Thickness	approx. 24,5 mm (≈1" - depending on selected surface material)
Slat width	25 mm (≈1")
Slat thickness	approx. 12.5 mm (1/2" - depending on selected surface material)
Slat spacing	10 mm (13/32")
Thickness acoustic felt	12 mm (15/32")
Weight	8,5 - 12,5 kg/m ² (1.74 - 2.56 lbs/ft ²) (depending on selected surface material and dimensions)

Other dimensions and constructions on request.

Acoustics

The charm of natural surfaces - in combination with the acoustic effectiveness of felt and the diffuse effect of the lamellas - make Acoustic-RibPanels a quick and easy way to improve room acoustics. Incident sound is guided through the gaps between the slats and absorbed by the felt behind them. Depending on the slat width and spacing, the acoustic effectiveness can be influenced as needed.

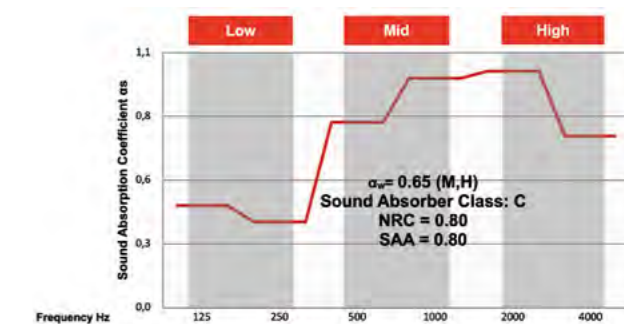

Further information

You can find all the information you need about Acoustic-RibPanel online.



>>> Website Acoustic-RibPanel

Questions? Get personal advice now.

+49 5428 9420-0





Easy processing



High sound absorption



Design variety

Acoustic-RibPanel Slim

Acoustic comfort, discreet design

Acoustic-RibPanels Slim consist of an acoustic felt support that can be covered with different surfaces and designed with individual slotted grids. These ready-to-use elements can be easily installed or further processed if required. Acoustic-RibPanels Slim can be installed as an accent, but also with an endless character without visual transitions.

Possible surfaces



HPL/ stained/ lacquered

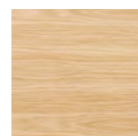

Real wood veneers

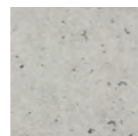

LightBeton®

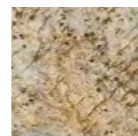

StoneVeneer



Felt

Material structure

Acoustic-RibPanels Slim consist of lamellas, which are individually manufactured with different surfaces and fixed on acoustic felt panels.

1. Surface material front side
2. PET felt black (alternatives on request)
3. Back side laminate or veneer

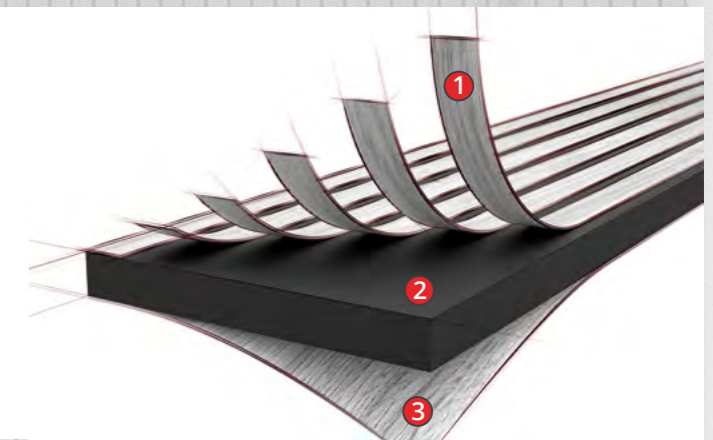

Mounting

Acoustic-RibPanels Slim can be easily mounted by nailing, tacking and screwing through the felt support or by fixing fasteners on the back. Direct bonding by means of a strong mounting adhesive is also possible.



Technical data

Length	2800 mm (110.2")
Width	210 mm (8.25")
Thickness	approx. 26,5 mm (≈1" - depending on selected surface material)
Slat width	25 mm (≈1")
Slat thickness	10 mm (13/32")
Thickness acoustic felt	25 mm (≈1")
Weight	5,5 - 9 kg/m ² (1.13 - 1.84 lbs/ft ²) (depending on selected surface material and dimensions)

Other dimensions and constructions on request.

Acoustics

With the charm of natural surfaces - in combination with the acoustic effectiveness of felt - Acoustic-RibPanels Slim provide a quick and easy way to improve room acoustics. Depending on the selected slot pattern, incident sound is absorbed by the acoustic felt support in the slot area or reflected by the surface. In addition to the desired appearance, the selected slot grid also has an impact on the acoustic properties.

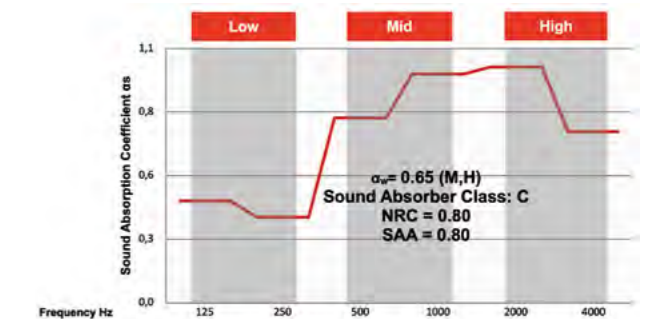

Further information

You can find all the information you need about Acoustic-RibPanel Slim online.



>>> Website Acoustic-RibPanel Slim

Questions? Get personal advice now.

+49 5428 9420-0





Design variety



High sound absorption

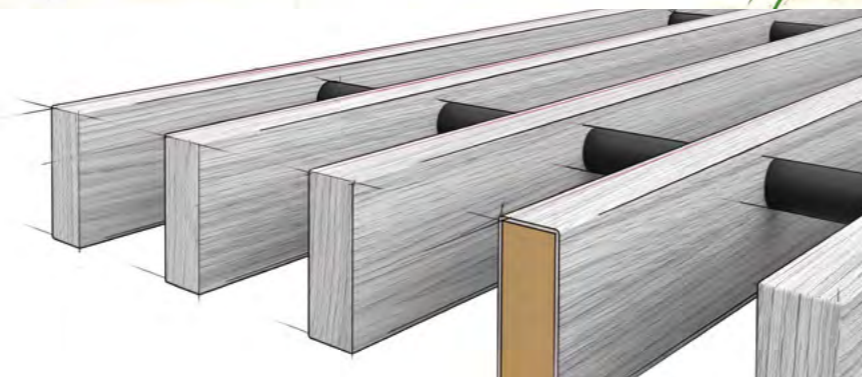

Acoustic-Grilles

Space design with pleasant sound effects

Acoustic-Grilles consist of vertical lamellas which can be manufactured individually with different surfaces and dimensions. The connection of the lamellas among each other is done either by means of aluminum tubes or wood material strips (backer). The course of the installed grilles appears seamless.

Possible surfaces



HPL / stained / lacquered

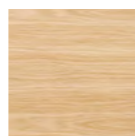

Real wood veneers

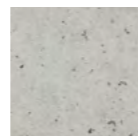

LightBeton®

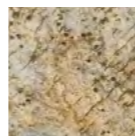

StoneVeneer



Material structure

Acoustic-Grilles consist of vertical lamellas, which can be manufactured individually with different surfaces, widths and lengths. A fleece lamination on the back can provide extended absorption performance.

1. Surface material front side
2. MDF / particle board
3. Back side laminate or veneer
4. Edging (veneer, ABS, melamine)

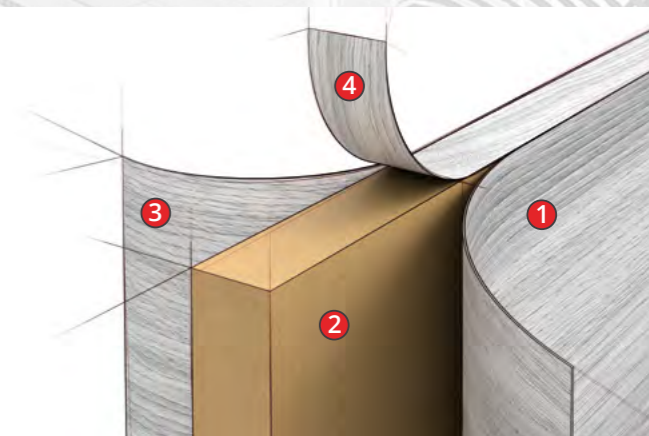

Mounting

Acoustic Grilles can be easily attached to corresponding 24 mm (≈1") T-profiles for grid system ceilings. Grilles can be fastened by means of J- or U-clips. These allow easy disassembly of individual grills for maintenance or similar purposes even after installation, if required.

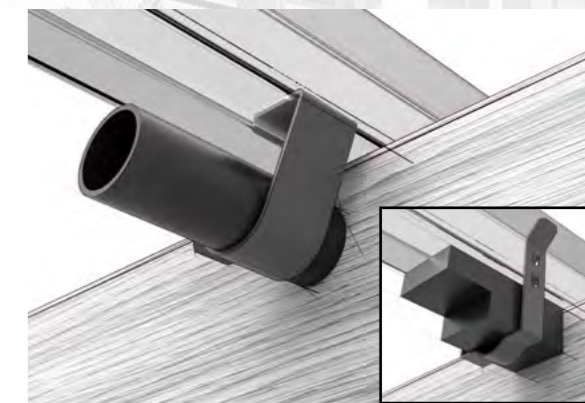

Lighting

Combination with area lighting and LED strips possible



Technical data

Length	500 – 2700 mm (19.7" to 106.3")
Width	305 mm (12" - depending on selected grid)
Slat height	45-150 mm (1.8" to 5.9")
Slat thickness	12-51 mm (15/32" to 2")
Weight	9 - 30 kg/m ² (1.84 - 6.15 lbs/ft ²) (depending on dimensions and selected grid)

Other dimensions and constructions on request.

Acoustics

Acoustic-Grilles offer an ideal acoustic solution with a natural charm. The height and arrangement of the louvers can influence the acoustic effectiveness and the desired atmosphere. Incident sound is reflected from the slats through the open areas between the slats behind the Acoustic-Grilles. Fleece lamination on the back or additional absorption material can provide extended absorption performance.

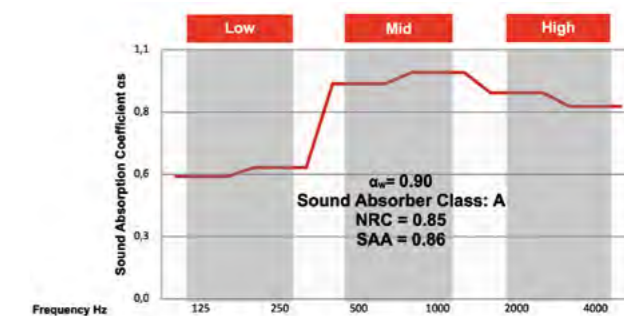

Further information

You can find all the information you need about Acoustic-Grilles online.



>>> Website Acoustic-Grilles

Questions? Get personal advice now.

+49 5428 9420-0



Acoustics

Micro-perforating and slitting

From the smallest hole diameters up to wide slits, our products offer a wide range of visual and acoustic design options.

Depending on the product type, there are several variants to choose from, each of which brings individual acoustic properties.

This is how you give your room an optimized sound.

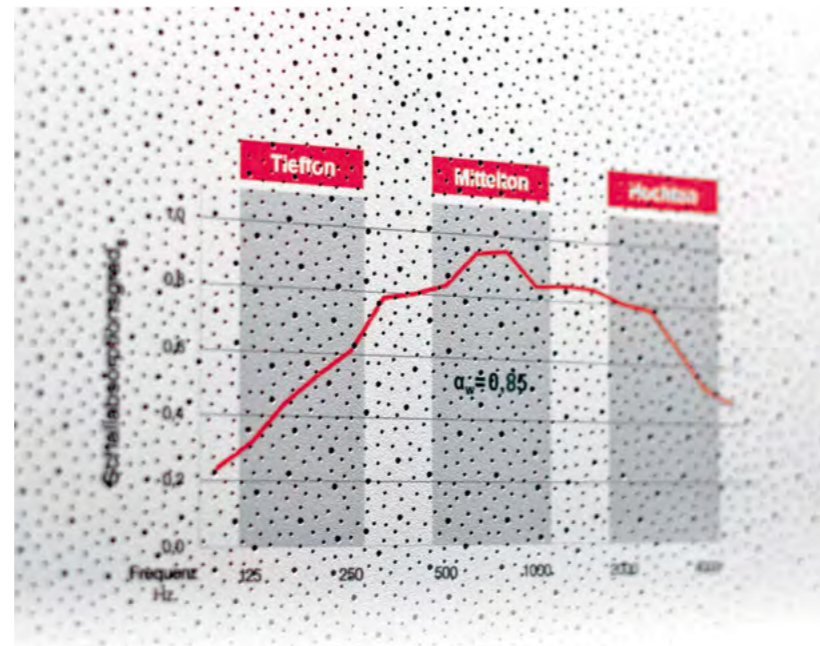

Perforations

Acoustic-Lightboard®
Acoustic-CompactBoard®
Acoustic-Baffles

Slits

Acoustic-CompactPanel®

Panels

Acoustic-RibPanel

Slits

Acoustic-RibPanel Slim

Random 1.0 	MR 050250V 	MR 075250 	SC 200090 	SC 010250 	SC 500250
MR 075500V 	MR 100300 	MR 100600 	SC 200140 	SC 900310 	SC 200090
MR 100600V 	MR 150500 	MR 150500V 	SC 300130 	SC 015025 	SC 200140
MS 075500 	MS 075500H 		SC 400280 		SC 300130
				Other panels possible on request.	SC 400280
					Other slits possible on request.

Surfaces

Our products are available in different finishes. Depending on the product type, different surface materials can be combined with different perforations or slits. Possible combinations can be found on the respective product pages or feel free to contact us directly with your inquiry.

From wood veneers, to HPL laminates and color lacquering according to RAL or NCS color codes, to our authentic LightBeton® and StoneVeneer surfaces, there is a variety of surface materials to choose from for your design.

Wood veneer

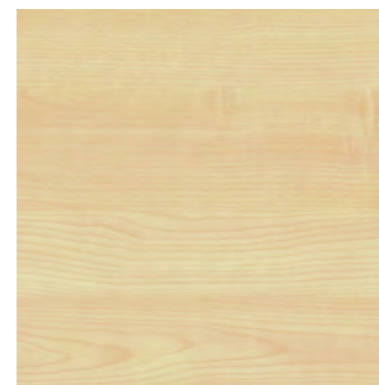

Maple

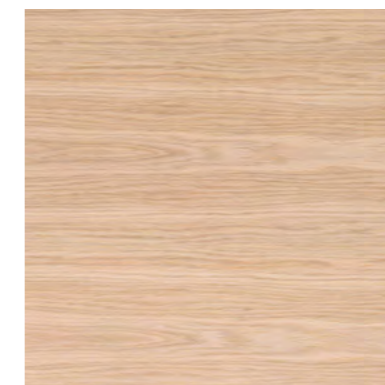

Oak



Cherry

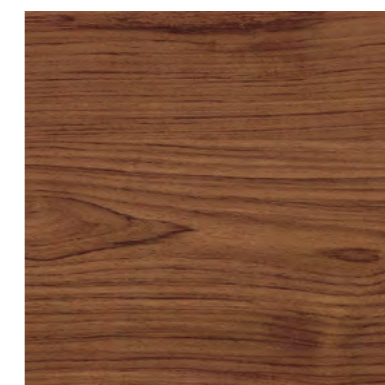

Walnut



Acoustic baffles with walnut veneer and microperforation MR 050250V

Other veneer finishes are available on request.

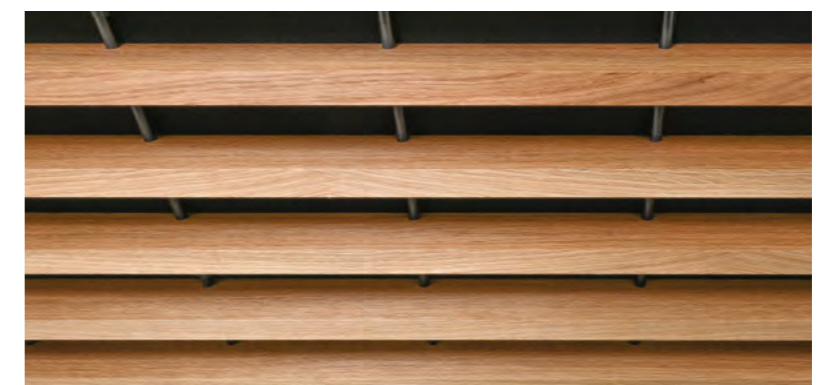

Acoustic-Grilles with oak veneer

Surfaces

LightBeton®



Classic grey

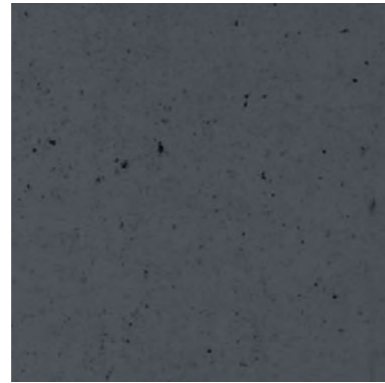

Classic anthracite



Classic white



Authentic



Retro

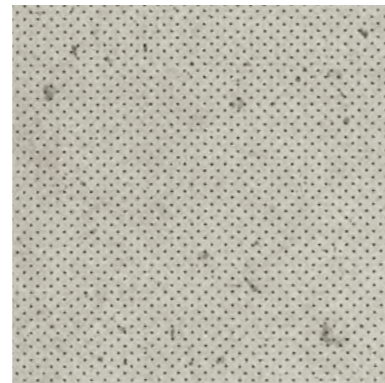

Acoustic (with microperforation)



Acoustic-Grilles in LightBeton® finish Classic grey

StoneVeneer



Autumn



Multi Color

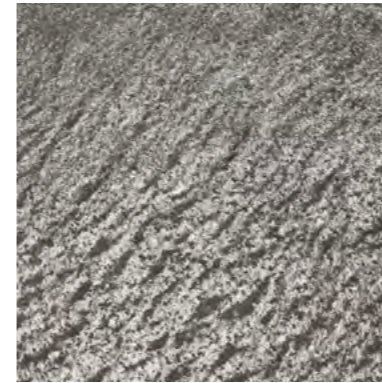

Black Star



Gold Green

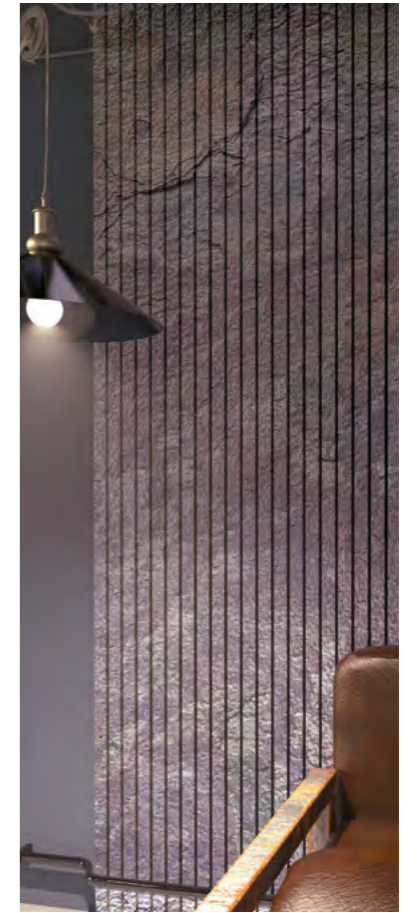

Acoustic-RibPanels in StoneVeneer finish Multi Color

Other stone veneer finishes are available upon request.

Acoustic felt panels

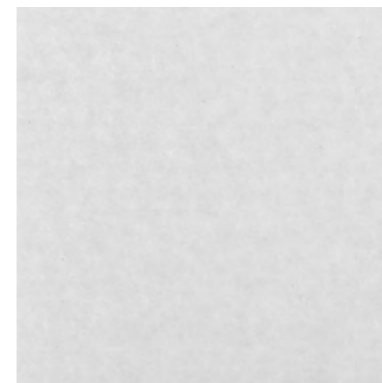

White



Mottled gray



Black

Acoustic felt panels can also be used for other applications and are available in other color shades.



Richter akustik & design was founded in 1984 and focuses on the development and production of innovative design surfaces and products for acoustics and fire protection.

With our experience, our customers can expect sophisticated and economical solutions for their ideas. Richter acts in a resource-conserving, sustainable and value-driven manner - out of responsibility for the environment and people.

And that in multiple award-winning product quality.



LightBeton®



StoneVeneer

Further highlights from Richter

We have already won many awards with unique surface technology, creative design surfaces, innovative acoustic solutions and reliable fire protection. However, it is important for us as the Richter akustik & design team that you, as an architect, interior designer, property fitter, shopfitter, exhibition stand builder or planner, benefit from our experience. So that your projects succeed.



12.2021 - GB

Richter akustik & design GmbH & Co. KG
St.-Annener-Straße 117 · 49326 Melle / St. Annen · Germany
www.richter-akustik-design.de | info@richter-akustik-design.de

